

Checkweigher Flexus® Combi

Hygienic design meets flexibility and metal detection



! Advantages

- Checkweigher and metal detector combined
- Highest performance with maximum design flexibility
- Blue HMI for maximum efficiency in production
- Safety and reliability thanks EMFR load cell technology

The high performance Flexus® Combi checkweigher series enables highly accurate weight control and metal detection in one hygienic frame at the same time. The new Blue HMI user interface increases efficiency, transparency and safety in production. All models and variants are optionally MID-approved.

The checkweigher Flexus® Combi is the flexible solution for product quality and safety

- ! Flexus® Combi is your solution for ensuring optimum product quality, regardless of whether you want to check the weight, detect metal foreign bodies, check the integrity of your product or optimise your filling processes.
- ! Flexus® Combi is incredibly easy to integrate into your production environment. Changes to line configurations and quick transitions between products are handled **with minimal effort**.
- ! Broad connectivity, e.g. OPC-UA, for integration into your processes and SPC@Enterprise Software.
- ! The high-resolution **EMFR load cell technology** and the **extremely sturdy construction** guarantee precise weighing results and a high throughput.

A new checkweigher with Blue HMI



Operating a checkweigher can be so simple
Whether introducing a new product, fine-tuning line parameters or establishing a batch protocol, the user interface of the new checkweigher is designed to be fast and easy. Bid farewell to time-consuming tasks and extensive staff training. Say hello to streamlined control with the new Minebea Intec Blue HMI by your side.



Makes your production more safe and efficient
Positioned at the end of the production line a checkweigher can narrate the story of your production. The Blue HMI displays your equipment's efficiency and other statistics based on your recent weighing results. It assists you through audits with several onboard protocol functions. We aim for you to be fully prepared and compliant at every step of the way.



Keep an eye on your weight
Blue HMI is a web-based cross-platform user interface with multi-user security. With this you are able to see everything your checkweigher does from authorized users within your network while your data is stored locally and securely on the checkweigher. This allows you to comfortably browse through configurations, weighing statistics or efficiency protocols. Moreover, you may connect to Minebea Intec's SPC@Enterprise, OPC UA clients, ProfiNET or Ethernet/IP gateways.

Flat stainless steel housing

High performance BOX PC

Full HD 15" Touch-Display

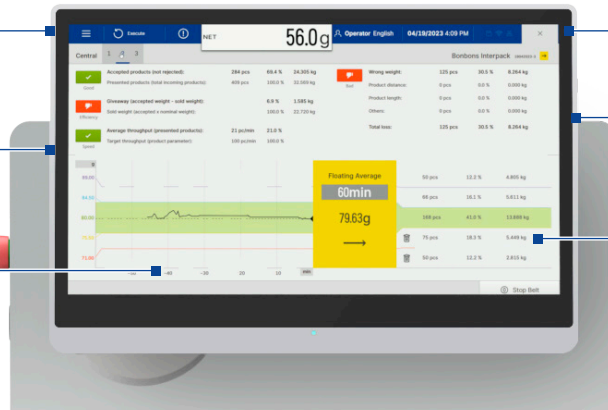

Optional tiltable screen

Flexible interfaces prepared for the future

Proven weighing technology

The new interface of Minebea Intec

As a global leading weighing supplier, we strive to offer reliable and flexible solutions for your production needs. However, flexibility in technical machinery often brings complexity.

Blue HMI serves as a cross-platform Human Machine Interface for all future products of Minebea Intec. Once started to use it, your daily work becomes easier.

Flexible – hygienic – high-performance

The checkweigher Flexus® Combi has been specially developed to comply with guidelines and standards such as IFS and BRC. It is approved for use in legal metrology for FPV (German Prepackages Act) checks and is MID-compliant in accordance with OIML R51. Remove metal contaminants with an integrated metal detector to increase the product safety at minimal space requirements. Thanks to its intelligent, modular construction and hygienic design, the Flexus® Combi can be configured to suit your individual requirements, providing you with the ideal solution for any challenge you face.

Technical data – Flexus®

The results achievable in practice, e.g. for the standard deviation attributable to measurement error or the throughput, depend on the relevant application.

Weighing system	WS 1 kg*	WS 2 kg	WS 5 kg	WS 7 kg
* The option Stainless Steel Conveyor (SSC) is not available for WS 1 kg				
Gross weighing range [g]	Up to 1,000	Up to 2,000	Up to 5,000	Up to 7,000
Smallest permissible calibration value [g]	0.1	0.2	0.5	1
Standard deviation attributable to measurement error(s) [mg]	From 17	From 83	From 250	From 333
	Depends on product, throughput, ambient conditions and area of application			
Standard throughput [pcs/min]	Max. 250	Max. 200	Max. 180	Max. 180
	Depends on version, product, permissible imprecision, ambient conditions and area of application			
Standard speed ranges [m/s]	0.2 to 1.5	0.2 to 1.0 0.5 to 1.5 (SSC option up to 1.5)	0.2 to 1.0 0.5 to 1.4 (SSC option up to 1.4)	0.2 to 1.0 0.5 to 1.4 (SSC option up to 1.4)
	All MID are possible.			
Centre-to-centre distance of weighing belt [mm]	210/310	300/350/400/450/500		
	See scale drawing and 'Versions' table			
Belt width [mm]	See 'Versions' table			
Weighing belt roller diameter [mm]	22	30		
Drives	Maintenance-free 24 V EC motors with planetary gear Motor control, short-circuit-proof with temperature monitoring			
Supply voltage	115/230 V _{ac} (+10%/-15%); 50/60 Hz (L1, N, PE) switchable			
Power consumption	Approx. 600 VA			
Operating pressure	Default setting: Pusher: approx. 3 bar Blower: approx. 5 bar			
Feed direction	Right to left or left to right (please indicate when ordering)			
Working height** [mm]	500 to 1,400 with standard adjustable feet 575 to 1,475 with hygienic adjustable feet (adjustable foot range ±25) ** Working height below 650 mm results in limited floor clearance when combined with the collection container option			
Floor clearance [mm]	200 with adjustable foot range ±25 (standard) 275 with adjustable foot range ±25 (hygienic adjustable feet)			
Permissible operating temperature range [°C]	0 to +40 (MID +5 to +40)			
Conveyor system temperature range [°C]	-10 to +100 (WS 1 kg, belt) -30 to +70 (WS 1 kg, round belt) -30 to +80 (WS 2 to 7 kg, belt)			
Protection class	IP 54 (standard), IP 65 (optional)			
Dimensions	See scale drawings			
Checkweigher frame material	Stainless steel 1.4301 (AISI 304)			
Transport system material	Standard: Belt body: aluminium (anodized) and stainless steel; Rollers: Aluminium (heartcoatiert); Bearing holder: Aluminium (anodized). SSC: Belt body: stainless steel; Rollers: Stainless steel; Bearing holder: POM. No additional infeed and outfeed belt possible with SSC Option.			
Reject bin material	Plastic (for products up to 500 g); Optional: Stainless steel with plastic door. Option SSC: Reinforced plastic; Optional: Stainless steel with plastic door.			
Weight	250 kg to 400 kg, depending on version			
Airborne noise emitted	A-weighted sound pressure level emitted < 70 dB(A)			
Inputs	8/16 (optional) digital inputs, 24 V inputs galvanically isolated with a relay or with optocoupler, depending on use			
Outputs	8/16 (optional) digital outputs, 24 V outputs galvanically isolated with a relay or with optocoupler, depending on use 2 analogue outputs, 0–20 mA, 0–10 V, for analogue trend controller option Voltage output: Load ≥ 2 kΩ Current output: Load ≤ 300 Ω			

Technical specifications – Checkweigher Flexus® Combi

Create your individual checkweigher Flexus® Combi from a wide range of options and function enhancements. We'd be happy to advise you!

Checkweigher Flexus® – standard	
Dialogue PC	Full HD 15" Touch-Display
Operational display	Choice of distribution, yield, throughput, average value chart, large weight readout, tare weight
Operating modes	AWC weigher Classifying weigher, freely selectable classification limits, x 3/5 sorting
Digital input	Control package, external event or ignore checkweigher, event counter, external fault reset
Digital output	Feeder/batch, 3-way/5-way sorting, total counter, error message output, time-unit-controlled sorting
Separation system	Standard: One separator including: pusher or blower (depending on product size) Option SSC: no blower available
Weighing belt	Various lengths and widths; Flat and round belt (for 1 kg system); blue and white (SSC only with blue)
Metal detector functions	Product effect minimisation, check using parts, test part check, metal accumulation, negative metal detection

Checkweigher Flexus® – optional for increased requirements		
Connectivity	Fieldbus	Profibus-DP, ProfiNET, Ethernet/IP
	Factory bus TCP/IP, Ethernet	SPC@Enterprise, OPC UA, PackML via OPC UA
	Individual weight value output for external evaluation and connection to customer systems	Serial interface RS 422, RS 232 or current loop (20mA)
	All interfaces specified here are free from feedback and do not need to be secured	
	Browser remote view	Read-only access to the checkweigher conveniently via the company network
	USB print	Created reports can be downloaded on a USB device
Software/programs	FTP export	Created reports are uploaded to a webserver
	Filling spout evaluation	Statistics for each filling spout and overall statistics possible
	Calibration approval	Verifiable in accordance with OIML R 51 – MID
	Control functions	Integrity checking/with floating mean value
	Volume evaluation	Without air buoyancy correction, with air buoyancy correction
	Trend controller with display	3-point controller ± control signal, 3-point controller with pulse packet, integral controller 0 – 20 mA/0 – 10 V
	3-way/5-way classifying display	3-way signal light, 5-way signal light, isolated outputs, isolated outputs with 3-way signal light, isolated outputs with 5-way signal light
	Separation system	Control of customer sorting/separating equipment
	Monitoring functions	
	Compressed air monitoring	Isolated output, belt stop
	Separation monitoring	Isolated output
	Goods flow	Isolated output with belt stop
	Package length/interval monitoring	Using additional light barrier
	Fill level monitoring* Collection container Incorrect weight	Isolated output with light
	Production monitoring	Monitoring of average value and repetitive rejections
Sorting with path cycle/ displacement sensor		
Mechanical designs	Emergency stop button	Mounted on the cabinet
	Incorrect weight collection container	Made from polycarbonate (for products up to 500 g and a maximum belt width of 200 mm) or stainless steel
	Separation systems	Rocker, swivel arm, multi-segment separator
	Transfer runways (not for SSC option)	Only for WS 1 kg/2 kg – up to a belt width of 200 mm
	Options	Wind protector, covers, LEDs, horn, IP65, guide rail, side-grip belts, stand-alone load cell and weighing belt, separate installation of weighing system and electronics with display and remote terminal, hygienic adjustable feet, additional infeed belt or outfeed belt, pneumatics in stainless steel housing, stainless steel conveyor (SSC)
Metal detection options	Type of metal detector	Vistus®, Mitus®
	Metal detector functions	Product flow monitoring, metal notification with separate acknowledgement, path cycle metal detector, collection container with password protection (digital lock), external inspection request, collection container fill level monitoring

* as well as pro version available, with an additional watchdog for the monitoring sensor

Scale drawings

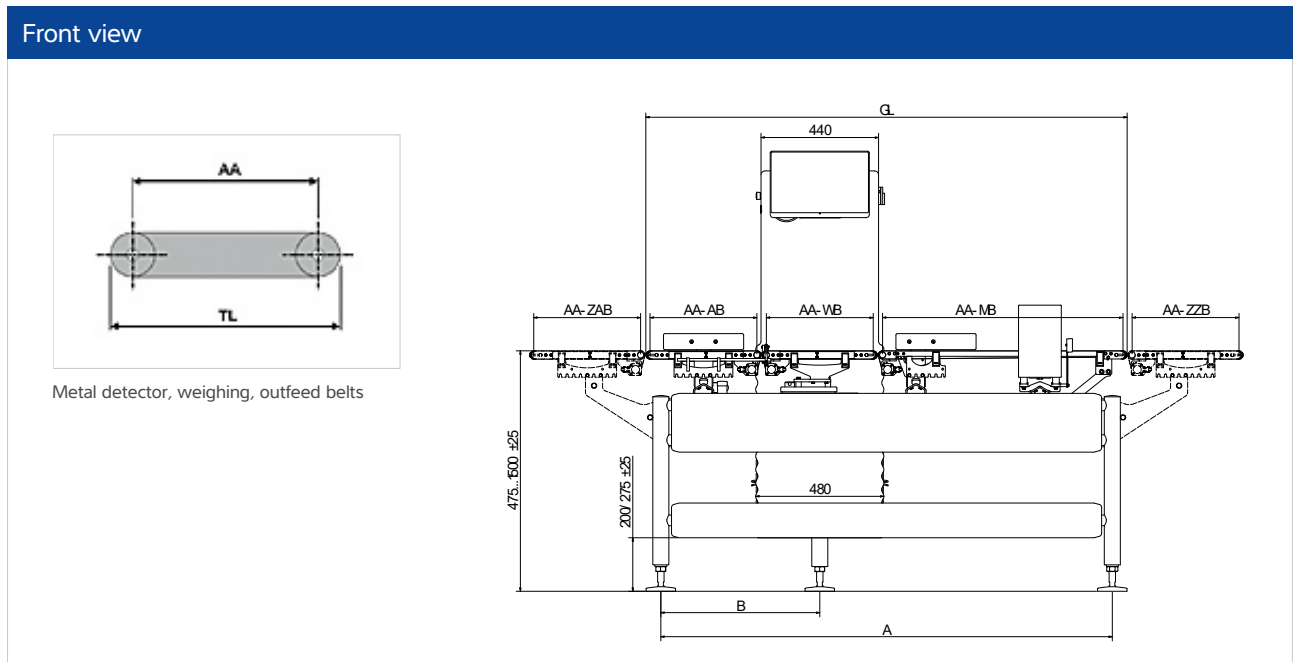

The figure shows a combi system with transport direction from left to right as an example.

AA-MB	Centre-to-centre distance of metal detector belt [mm]
AA-WB	Centre-to-centre distance of weighing belt [mm]
AA-AB	Centre-to-centre distance of outfeed belt [mm]
AA-ZAB	Centre-to-centre distance of extra outfeed belt [mm]
AA-ZZB	Centre-to-centre distance of extra infeed belt [mm]
C	Metal detector coil passage height [mm]
A	Variable; see scale drawing [mm]
B	Variable; see scale drawing [mm]
GL	Total length [mm]
U	Metal detector coil installed upright
TL	Platform length [mm] TL = AA + roller diameter (30 mm, or 22 mm in the case of the 1 kg weighing belt)

For belt widths BB = 150/200/250/300, additional lengths are available for outfeed belts with centre-to-centre distance AA = 550/600/650/700.

Dimensions table: WS 1 kg

AA-MB	AA-WB	AA-AB	C	A	B	GL
900	210	350	90, 125, 150	1,440	445	1,550
		400		1,490	495	1,600
		450		1,540	545	1,650
		500		1,590	595	1,700
1,000	210	350	90, 125, 150	1,540	445	1,650
		400		1,590	495	1,700
		450		1,640	545	1,750
		500		1,690	595	1,800
1,100	210	350	90, 125, 150, 200, 275u, 375u	1,640	445	1,750
		400		1,690	495	1,800
		450		1,740	545	1,850
		500		1,790	595	1,900
800	310	300	90, 125, 150	1,390	445	1,500
		350		1,440	495	1,550
		400		1,490	545	1,600
		450		1,540	595	1,650
		500		1,590	645	1,700
900	310	300	90, 125, 150	1,490	445	1,600
		350		1,540	495	1,650
		400		1,590	545	1,700
		450		1,640	595	1,750
		500		1,690	645	1,800
1,000	310	300	90, 125, 150, 200, 275u, 375u	1,590	445	1,700
		350		1,640	495	1,750
		400		1,690	545	1,800
		450		1,740	595	1,850
		500		1,790	645	1,900
1,100	310	300	90, 125, 150, 200, 275u, 375u	1,690	445	1,800
		350		1,740	495	1,850
		400		1,790	545	1,900
		450		1,840	595	1,950
		500		1,890	645	2,000

Dimensions table: WS 2/5/7 kg

AA-MB	AA-WB	AA-AB	C	A	B	GL
800	300	300	90, 125, 150	1,390	445	1,500
		350		1,440	495	1,550
		400		1,490	545	1,600
		450		1,540	595	1,650
		500		1,590	645	1,700
900	300	300	90, 125, 150	1,490	445	1,600
		350		1,540	495	1,650
		400		1,590	545	1,700
		450		1,640	595	1,750
		500		1,690	645	1,800
1,000	300	300	90, 125, 150, 200, 275u, 375u	1,590	445	1,700
		350		1,640	495	1,750
		400		1,690	545	1,800
		450		1,740	595	1,850
		500		1,790	645	1,900
1,100	300	300	90, 125, 150, 200, 275u, 375u	1,690	445	1,800
		350		1,740	495	1,850
		400		1,790	545	1,900
		450		1,840	595	1,950
		500		1,890	645	2,000
800	350	350	90, 125, 150	1,490	520	1,600
		400		1,540	570	1,650
		450		1,590	620	1,700
		500		1,640	670	1,750
		550		1,690	720	1,800
900	350	350	90, 125, 150	1,590	520	1,700
		400		1,640	570	1,750
		450		1,690	620	1,800
		500		1,740	670	1,850
		550		1,790	720	1,900
1,000	350	350	90, 125, 150, 200, 275u, 375u	1,690	520	1,800
		400		1,740	570	1,850
		450		1,790	620	1,900
		500		1,840	670	1,950
		550		1,890	720	2,000
1,100	350	350	90, 125, 150, 200, 275u, 375u	1,790	520	1,900
		400		1,840	570	1,950
		450		1,890	620	2,000
		500		1,940	670	2,050
		550		1,990	720	2,100
900	400	400	90, 125, 150	1,690	595	1,800
		450		1,740	645	1,850
		500		1,790	695	1,900
1,000	400	400	90, 125, 150	1,790	595	1,900
		450		1,840	645	1,950
		500		1,890	695	2,000
1,100	400	400	90, 125, 150, 200, 275u, 375u	1,890	595	2,000
		450		1,940	645	2,050
		500		1,990	695	2,100
900	450	450	90, 125, 150	1,790	670	1,900
		500		1,840	720	1,950
1,000	450	450	90, 125, 150	1,890	670	2,000
		500		1,940	720	2,050
1,100	450	450	90, 125, 150, 200, 275u, 375u	1,990	670	2,100
		500		2,040	720	2,150
900	500	500	90, 125, 150	1,890	745	2,000
1,000	500	500	90, 125, 150	1,990	745	2,100
1,100	500	500	90, 125, 150, 200, 275u, 375u	2,090	745	2,200

Side view

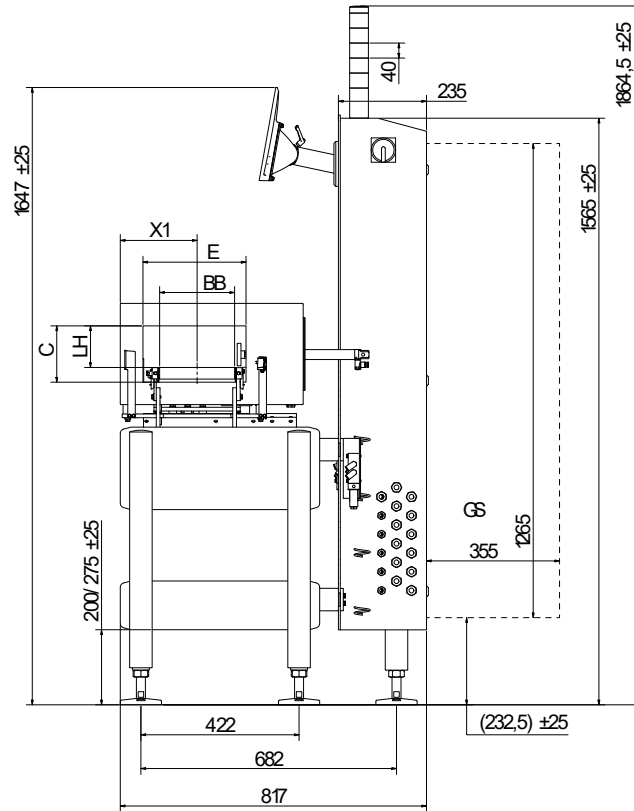

BB-MB	Metal detector belt width [mm]
BB-WB	Weighing belt width [mm]
E	Metal detector coil passage width [mm]
C	Metal detector coil passage height [mm]
LH	Clear height [mm]
F	Variable; see dimensional drawing [mm]
X1	Variable; see dimensional drawing [mm]
U	Metal detector coil installed upright
GS	Space requirement for opened cabinet door

Dimensions table: WS 1 kg

BB-MB	BB-WB	E	C	LH	X1
150	50	225	90	50	180
			125	85	
			150	110	
		200	160		
		275u	235		
150	100	225	375u	335	
			90	50	
			125	85	
		150	110		
		200	160		
		275u	235		
		375u	335		

Dimensions table: WS 2/5/7 kg

BB-MB	BB-WB	E	C	LH	X1
150	150	225	90	50	180
			125	85	
			150	110	
		200	200	160	
			275u	235	
			375u	335	
200	200	275	90	50	205
			125	85	
			150	110	
			200	160	
150	150	225	90	50	180
			125	85	
			150	110	
		200	200	160	
			275u	235	
			375u	335	
200	200	275	90	50	205
			125	85	
			150	110	
			200	160	
250	250	325	90	50	230
			125	85	
			150	110	
			200	160	
300	300	375	90	50	255
			125	85	
			150	110	
			200	160	

Versions

AA	Centre-to-centre distance [mm]
BB	Belt width [mm]
C	Metal detector coil passage height [mm]
U	Metal detector coil installed upright
●	Round belt or belt version
■	Belt version

WS 1 kg

BB x AA [mm]			C
Metal detector belt ■	Weighing belt ●	Outfeed belt ■	
150 x 800	50 x 310	150 x 300/350/400/450/500	90/125/150
	100 x 310		
	150 x 310		
150 x 900	50 x 210	150 x 350/400/450/500	90/125/150
	100 x 210		
	150 x 210		
150 x 900	50 x 310	150 x 300/350/400/450/500	90/125/150
	100 x 310		
	150 x 310		
150 x 1,000	50 x 210	150 x 350/400/450/500	90/125/150
	100 x 210		
	150 x 210		

BB x AA [mm]			C
Metal detector belt ■	Weighing belt ●	Outfeed belt ■	
150 x 1,000	50 x 310	150 x 300/350/400/450/500	90/125/150/200/275u/375u
	100 x 310		
	150 x 310		
150 x 1,100	50 x 210	150 x 350/400/450/500	90/125/150/200/275u/375u
	100 x 210		
	150 x 210		
150 x 1,100	50 x 310	150 x 300/350/400/450/500	90/125/150/200/275u/375u
	100 x 310		
	150 x 310		
200 x 800	200 x 310	200 x 300/350/400/450/500	90/125/150
200 x 900	200 x 210	200 x 350/400/450/500	90/125/150
200 x 900	200 x 310	200 x 300/350/400/450/500	90/125/150
200 x 1,000	200 x 210	200 x 350/400/450/500	90/125/150
200 x 1,000	200 x 310	200 x 300/350/400/450/500	90/125/150/200/275u/375u
200 x 1,100	200 x 210	200 x 350/400/450/500	90/125/150/200/275u/375u
200 x 1,100	200 x 310	200 x 300/350/400/450/500	90/125/150/200/275u/375u

WS 2/5/7 kg

AA [mm]				C		
BB [mm]	Metal detector belt ■	Weighing belt ■	Outfeed belt ■			
150	800	300	300/350/400/450/500	90/125/150		
		350	350/400/450			
	900	300	300	300/350/400/450/500	90/125/150	
			350	350/400/450/500		
			400	400/450/500		
			450	450/500		
	1,000	300	300	300/350/400/450/500	90/125/150/200/275u/375u	
			350	350/400/450/500		
			400	400	400/450/500	90/125/150
				450	450/500	
	1,100	300	300	300/350/400/450/500	90/125/150/200/275u/375u	
			350	350/400/450/500		
400			400/450/500			
450			450/500			
200	800	300	300/350/400/450/500	90/125/150		
		350	350/400/450/500			
	900	300	300	300/350/400/450/500	90/125/150	
			350	350/400/450/500		
			400	400/450/500		
			450	450/500		
	1,000	300	300	300/350/400/450/500	90/125/150/200	
			350	350/400/450/500		
			400	400	400/450/500	90/125/150
				450	450/500	
	1,100	300	300	300/350/400/450/500	90/125/150/200	
			350	350/400/450/500		
400			400/450/500			
450			450/500			
1,100	300	300	300/350/400/450/500	90/125/150/200		
		350	350/400/450/500			
		400	400/450/500			
		450	450/500			
1,100	300	300	300/350/400/450/500	90/125/150/200		
		350	350/400/450/500			
		400	400/450/500			
		450	450/500			
1,100	300	300	300/350/400/450/500	90/125/150/200		
		350	350/400/450/500			
		400	400/450/500			
		450	450/500			

WS 2/5/7 kg

AA [mm]				C	
BB [mm]	Metal detector belt ■	Weighing belt ■	Outfeed belt ■		
250	800	300	300/350/400/450/500	90/125/150	
		350	350/400/450/500		
	900	300	300/350/400/450/500		90/125/150/200
		350	350/400/450/500		
		400	400/450/500		
		450	450/500		
	1,000	500	500	90/125/150	
		300	300/350/400/450/500		
		350	350/400/450/500		
		400	400/450/500		
	1,100	450	450/500	90/125/150/200	
		500	500		
		300	300/350/400/450/500		
		350	350/400/450/500		
	300	800	400	400/450/500	90/125/150
			450	450/500	
500			500		
900		350	350/400/450/500	90/125/150/200	
		400	400/450/500		
		450	450/500		
1,000		500	500	90/125/150	
		350	350/400/450/500		
		400	400/450/500		
1,100		450	450/500	90/125/150/200	
		500	500		
		350	350/400/450/500		
	400	400/450/500			

WS 2/5/7 kg – Option stainless steel conveyor (SSC)

AA [mm]				C
BB [mm]	Metal detector belt ■	Weighing belt ■	Outfeed belt ■	
200	900	300	300	90/125/150
	1,000	400	400	
		500	500	
300	1,000	400	400	90/125/150
		500	500	
200	1,100	300	300	200
	1,200	400	400	
		500	500	
300	1,200	400	400	200
		500	500	

BB [mm]	Product height [mm]	Opening Metal detector [cm]
200	35	40 x 9
	70	40 x 12.5
	95	40 x 15
	145	40 x 20
300	35	60 x 9
	70	60 x 12.5
	95	60 x 15
	145	60 x 20

Stainless Steel Conveyor – Features and Benefits

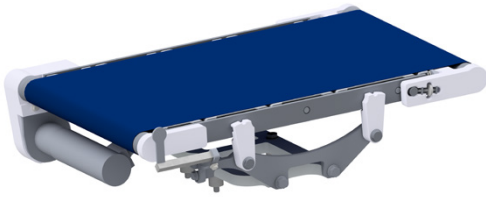

- Resistant to chemical detergents
- Weighing range from 50 g to 7 kg
- Easy belt change and cleaning
- Temperature range MID approved version: 5 °C to 40 °C
- Temperature range non approved version: -10 °C to 40 °C
- IP65 water protection with AISI 304 Stainless Steel

Collection container

The scale drawing shows Flexus® Combi with a collection container (optional), which is made from plastic or stainless steel – both versions have different dimensions.

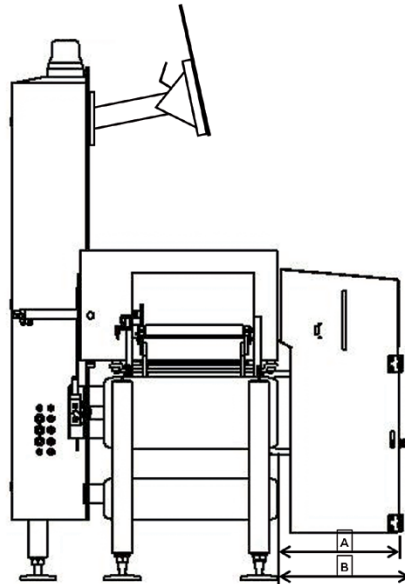

A	Minimum depth of the collection container
B	Maximum depth (incl. key) of the collection container

Material	A [mm]	B [mm]
Plastic	272	303
Stainless steel	372	403



Extend your checkweigher with our Software SPC@Enterprise to ensure your product quality, food safety and efficiency.

Get your first impressions about **SPC@Enterprise Software!**



Experience seamless connectivity with OPC UA, based on the Companion Specification for scales. Our smart scales offer precise data integration and simplify your processes. Connect your production effortlessly and maximize efficiency with OPC UA!

Display option



Ergonomic working with Blue HMI

Ergonomic adjustment

Tilting display enables optimum positioning for every operator.

Environmental flexibility

Adaptation to different lighting conditions and environments.

Customised comfort

Improved user-friendliness and working comfort for efficient processes.

	Tiltable display	Rigid display
Synus®	Optional	Standard
Flexus®	Standard	Optional
EWK (mounted on frame)*	Standard	Optional
EWK (terminal standalone)*	Standard	Optional

* Additionally limited swivelling and lockable around the vertical axis

Overall Equipment Effectiveness (OEE)

The OEE helps you to optimize your manufacturing efficiency by providing a simple, comprehensive metric that measures the performance, availability and quality of the end of line. OEE helps to identify areas for improvement, reduce downtime, increase productivity and ultimately boost profitability.



Overall Equipment Effectiveness(OEE)

=



×



×



Availability

It measures operational time as a fraction of planned production time, accounting for scheduled breaks like lunch, maintenance and cleaning.

Performance

It measures the actual line speed as a fraction of the optimal line speed.

Quality

It measures the number of saleable pieces produced as a fraction of the total produced pieces.

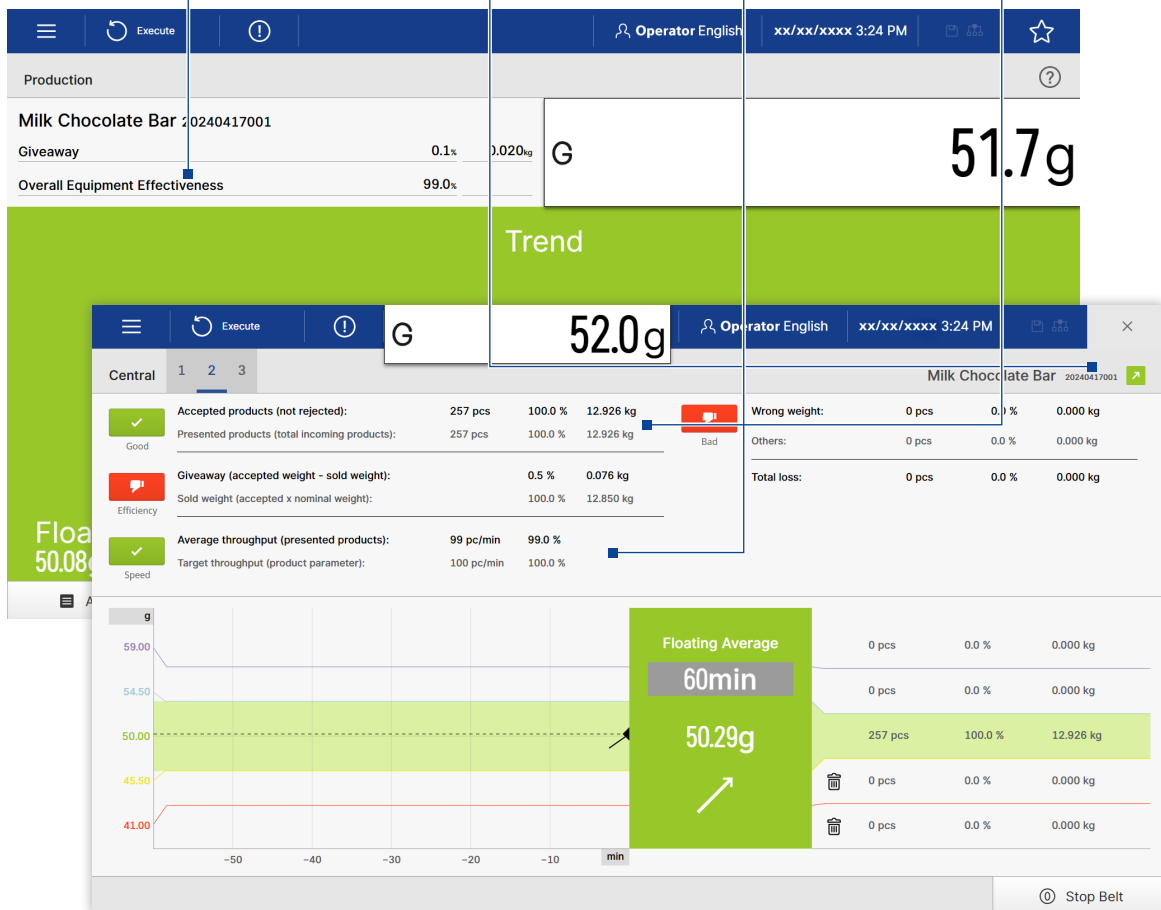

Product description

Machine construction

The Flexus® Combi comprises the checkweigher Flexus® combined with integrated Metal detector Vistus®-S. It is operated using a joint terminal. The system is therefore used not only to detect products contaminated with metal, but also to transport and weigh goods to be conveyed.

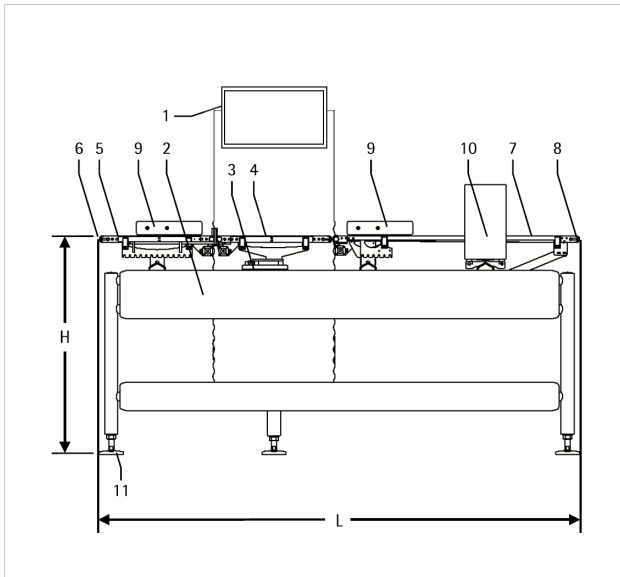

- 1 Operator terminal
 - 2 Checkweigher frame
 - 3 Load cell
 - 4 Weighing belt
 - 5 Outfeed belt
 - 6 Connection point for customer's outfeed belt
 - 7 Metal detector belt
 - 8 Connection point for customer infeed belt
 - 9 Rejection device
 - 10 Metal detector
 - 11 Spindle adjustable feet
- H Conveyor height
L Installation length checkweigher
(based on transport direction Right > Left machine)

A three-part conveyor belt system transports the products from right to left. All conveyor belts (4, 5, 7) in the system run at the same speed to ensure that products are transferred smoothly onto and off of the weighing belt. The weighing process is carried out dynamically and automatically without intervention by operating personnel. The weight value, including mass unit, is converted and shown on the display.

Weigher frame with control cabinet

Crossbars are fitted to the weigher frame (2). The weighing and transport system is attached to these crossbars. The pillar cabinet with its sinusoidal housing profile is attached to the weigher frame using a clamping device. The working height of the weigher frame is determined by the length of the frame legs. The working height can be adjusted by changing or modifying the frame legs. Small adjustments to the working height can be made via the spindle adjustable feet (11). The display and remote terminal (1) is installed in front of the control cabinet.

Load cell

The load cell (3) is a monolithic, electro-magnetic force compensation load cell (EMFC). This delivers maximum precision, extremely short settling times, high long-term stability and overload protection in a stainless steel housing.

Transport system

A conveyor belt is used as the transport medium (weighing belt WS 1 kg also available with round belt). The belt frame is equipped with a belt quick-clamping device and a hinged, removable transport system. This allows the conveyor belts to be removed/fitted and replaced without tools. A 'non-antistatic' belt must be used as the metal detector belt. 'Non-antistatic' belts have no influence on the magnetic field of the detector coil and are therefore optimally suited for use in conjunction with metal detectors. It must be ensured that the 'non-antistatic' belt does not become electrically charged resulting in electrostatic discharge. If an 'antistatic' belt needs to be used for technical procedural reasons, then it must be anticipated that there will be interference with the sensitivity due to the disruptive signal caused by the belt connection points. The conveyor belt must not have any metallic inclusions. Metallic inclusions may occur if there is welding or grinding on the belt structure and welding or grinding beads fall on the belt and anneal there. The metal detector, weighing and outfeed belts are each driven by an EC geared motor. Power is transmitted via toothed belt.

- The metal detection (7) conveyor takes the products from the upstream machine or from the upstream optional additional infeed belt and passes them through the metal search coil.
- The weighing belt (4) takes the products from the metal detection conveyor. While the products are on the weighing belt, they are weighed while in motion. The weighing belt can optionally be set up separately from the weigher frame.
- The outfeed belt (5) takes the products and transports them further to the downstream optional additional outfeed belt or to the downstream customer belt.

Control electronics

The display and remote terminal for the weighing function is based on an industrial PC with a powerful 32-bit multitasking operating system with data storage on an internal wear-free compact flash memory card. The housing is made from polished stainless steel. The control cabinet is opened using a continuous cabinet door opening to the rear with fasteners. The connection terminals for the power supply, the components of the evaluation and display electronics and the power supply unit with motor control are housed in the control cabinet. The main switch is installed in the control cabinet. The start/stop button for the transport system is located on the front of the display and remote terminal (1), which can be swivelled for ergonomic operation.

Rejection device

Two compressed air nozzles (standard WS 1 kg) or two pneumatic pushers (standard WS 2–7 kg) are fitted on the metal detector conveyor belt area and in the outfeed conveyor area to ensure the reliable rejection of products with different weights or that are contaminated with metal. A filter pressure control valve is included.

Metal detector

Metal detectors (10) protect consumers against damage to health caused by metal parts, prevent the end product from being contaminated by metal and protect processing machines against damage. As well as magnetic metal parts, metal detectors also detect high-alloy steels and non-ferrous metals (copper, brass, aluminium, lead etc.).

Rubber-bonded metal elements

To prevent the metal detector from being influenced by vibrations of the belt structure and to insulate the metal detector electrically against the belt structure, the metal detector must be equipped with four rubber-bonded metal elements at the factory.

The metal detector is secured to the belt structure or to a separate bracket using the rubber-bonded metal elements.

The products and solutions presented in this data sheet make major contributions in the following sectors:



The technical data given serves as a product description only and should not be understood as guaranteed properties in the legal sense.

Specifications subject to change without notice.
Rev. 08/2024

Minebea Intec Aachen GmbH & Co. KG
Am Gut Wolf 11
52070 Aachen, Germany
Phone +49.241.1827.0
sales.ac@minebea-intec.com
www.minebea-intec.com